

Thrust Line around an Arched Opening—Symmetric

Like recent releases of *Firefox* and *Opera* do, your browser must support *Scalable Vector Graphics (SVG)* to display the drawing.

Thrust Line			
	Horizontal Reaction		Peak Height
	(lbf)	(N)	(m)
Failure	2,801	12,462	4
	10,577	47,048	3.56
Stability	5,126	22,803	3.827
	5,834	25,950	3.78

At present, the stability thrust lines on the left side of the diagram are limited to the inner third of the faces of the voussoirs; the arch load is not considered rigid. Also, for determining the inner third of the buttress, its effective width is assumed to be always decreasing with height. This shape is indicated by a dotted line if it differs from the outline of the buttress.

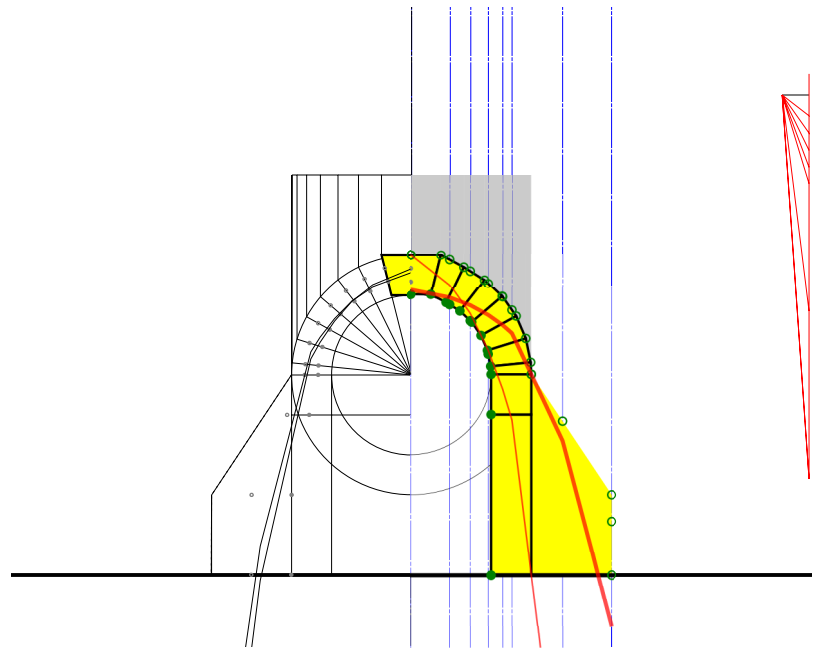

Submit Query Reset Defaults

Units:

Voussoirs

Number of voussoirs This number includes the springers and keystone(s) and must be at least 3 (though four does not draw correctly). Odd numbers result in arches with a single keystone, while even numbers result in pointed arches and the "keystones" are the stones on either side of the point at the top. The maximum number of voussoirs is 51.

m thick spanning a width of m of m thickness of

Width × Height m

These values control the extrados of the arch. The width is the horizontal radial depth of the arch stones (the minimum springer width) and the height is the vertical radial depth of the arch stones (the minimum keystone height).

Arch Intrados

Center Offset (,); Radii (,)

When these radii are the same, the arch will outline part of a circle. Also, offset value implementation is still rather buggy, as are most cases when the intrados horizontal radius is not equal to half of the spanned width.

Keystone(s)

Width × Height m m thick

Note this is the width of both top voussoirs together when there is no keystone (the number of voussoirs is even).

Springers

Springers and keystones must be at least as deep (radially) as the rest of the voussoirs.

Width × Height m m thick

Capitals

m tall

Columns

Width × Height m m thick ;

Arch Loads

m thick

Heights , , , , , , , , m

Buttresses

m thick

Segments @ (Width×Height)

@ (×) , (*m*×*m*)

[Defaults](#)

The thrust line is the axis of greatest compressive stress. It cannot pass outside of a structure, and the structure will deform if possible to keep these forces within it. A structure is assumed stable if the thrust line remains within the inner third of rigid compressive elements.

- [Wiki page notes](#)

This web application is untested and unverified pre-alpha experimental software intended only to help visualize the forces in compressive stone structures. Do not rely on it to analyze or design anything.

©2009 David Wagner, BSCE, EIT



The inline SVG does not allow [page validation as X/HTML](#).